



Basic Ham Radio Licensing Course

Mark Bramwell
VE3PZR

November 2017

Ham Course Power-Point Slides - Mozilla Firefox

File Edit View History Bookmarks Tools Help

Ham Course Power-Point Slides

Back Forward Reload Stop Home

www.foxhollow.ca/hamcourse/ Google

LARC Ham-Radio Course

Active Devices & Power Supplies

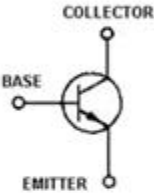
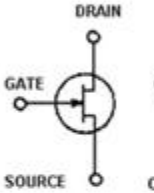
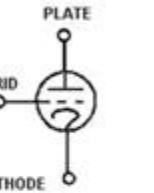
COLLECTOR	DRAIN	PLATE
		
EMITTER	SOURCE	CATHODE
<u>BIPOLAR</u>	<u>JFET</u>	<u>VACUUM TUBE</u>

[Click here for the PDF](#)
(1.5meg download)



Topics to be covered...

- Active Devices: Diodes, Transistors and Tubes
- Power Supplies: Changing AC to DC

Objectives...

- Become familiar with the basics of semiconductors and tubes
- Name the parts of each
- Compare tubes and solid state devices

What is a semiconductor?

- The purpose of electronics is to control the flow of current in one way or another so that intelligence or information can be impressed upon the current flow
- What is a conductor?
- What is an insulator?
- Is there something that is both?
- A semiconductor allows current to flow under certain conditions

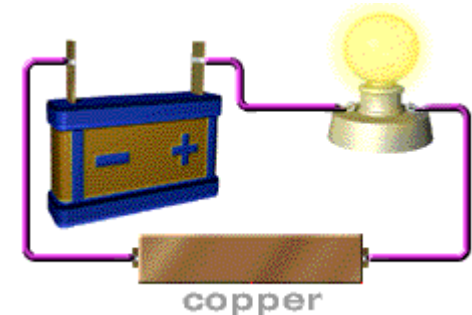
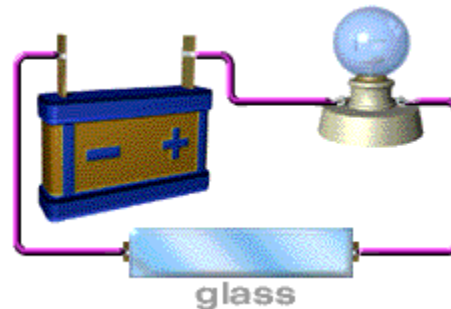
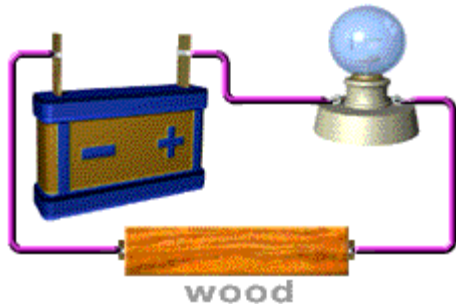

Silicon is an insulator?

- Carbon, silicon and germanium each have four electrons in their outer orbital allowing them to form nice crystals.

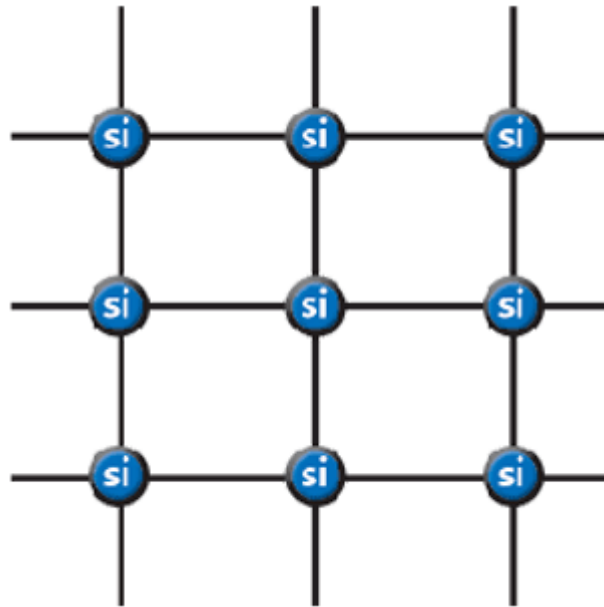

Silicon on Dope

- Doping means adding impurities to modify the behavior of a substance
- Electrons are negative. Removing electrons makes something comparatively 'positive'
- Electrons and water both want to seek their own level; under the proper circumstances, the current will flow

Types of Doped material...

- N-Type: Extra electron added; can not bond to anything; free to move around
- P-Type: Electron missing from crystal lattice; a nice hole to accept free moving electrons

Diodes

- Created by the junction of N + P type material.
- Part Numbers: 1N4001, 1N914
- “1” means one junction

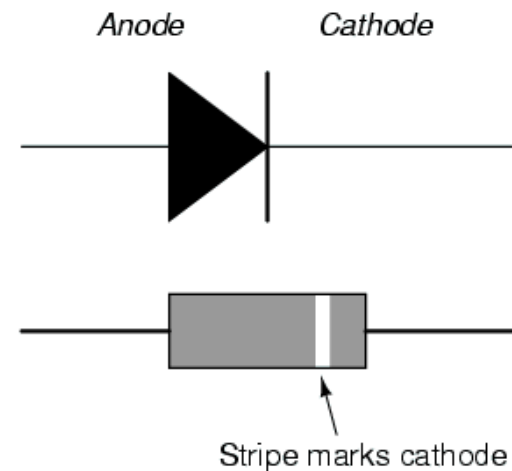
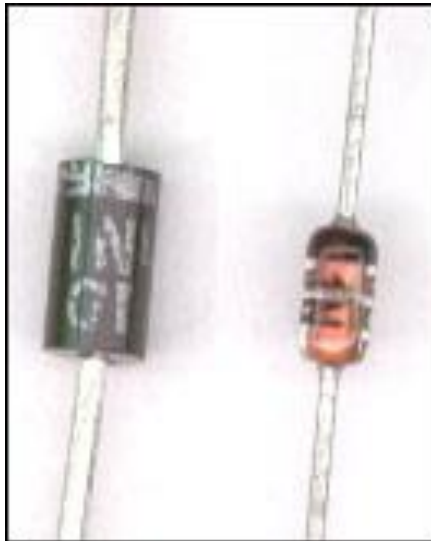

Diode Operation

- Current Flow versus Electron Flow

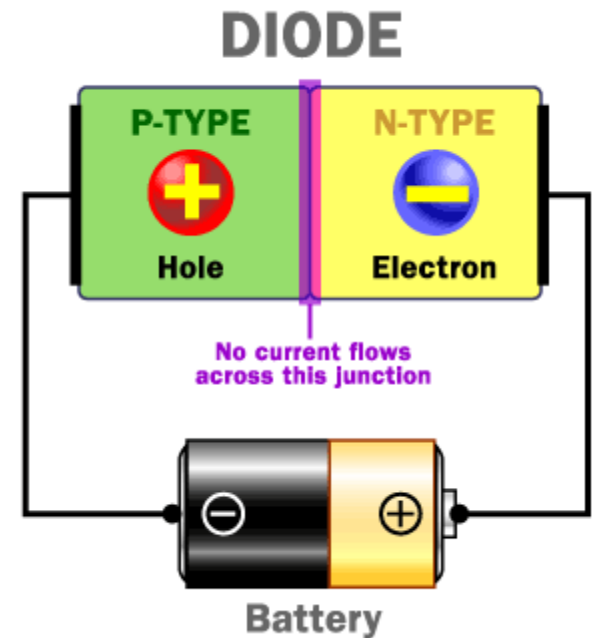
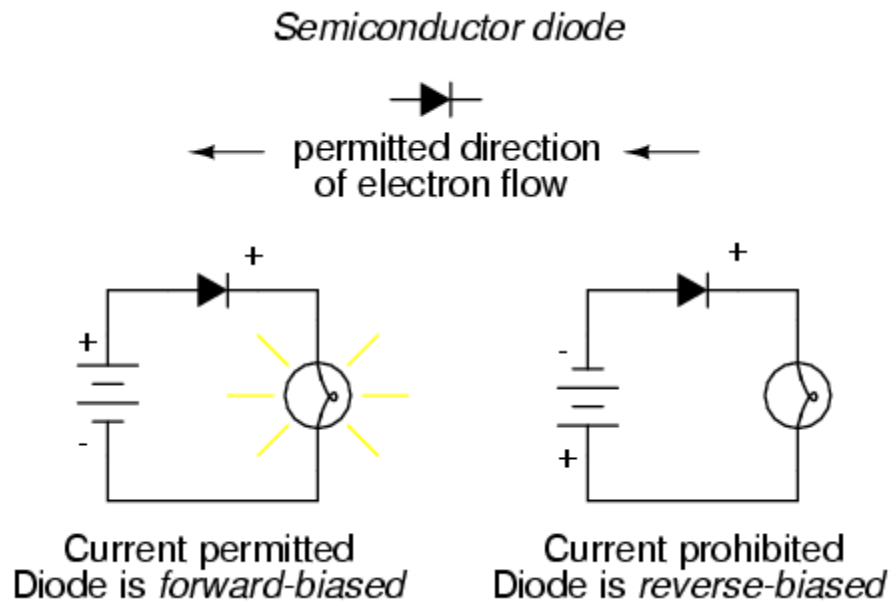



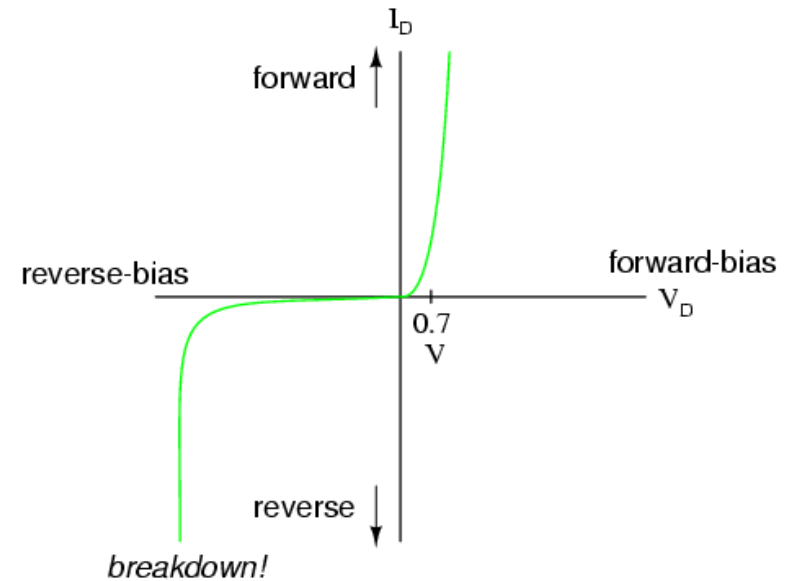
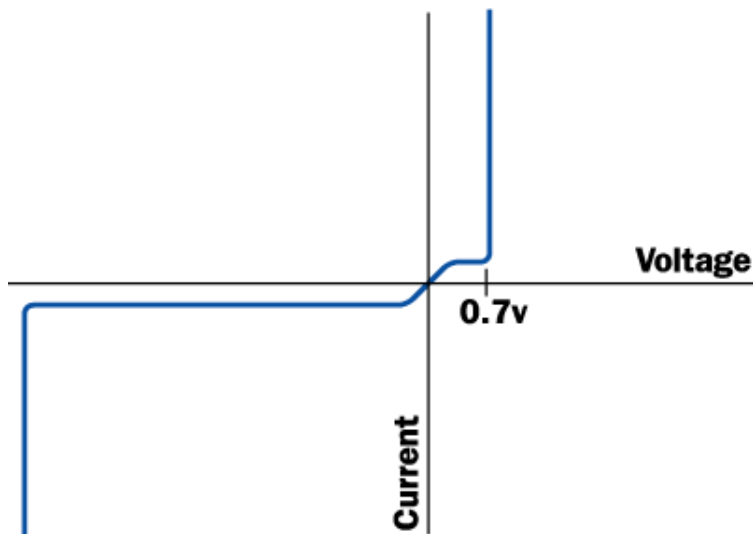

Diode Voltage Drop



All Diodes have a voltage drop, in this case it is .7volts

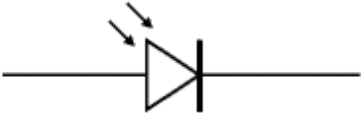

Types of Diodes

Diodes		
Component	Circuit Symbol	Function of Component
Diode		A device which only allows current to flow in one direction.
LED Light Emitting Diode		A transducer which converts electrical energy to light.
Zener Diode		A special diode which is used to maintain a fixed voltage across its terminals.
Photodiode		A light-sensitive diode.
Varactor		Variable Capacitor

Varactors / Varicaps are commonly used in parametric amplifiers, parametric oscillators and voltage-controlled oscillators as part of phase-locked loops and frequency synthesizers. It is principally used as a voltage-controlled capacitor, and its rectifier function is secondary.

Diode key terms

- A *diode* is an electrical component acting as a one-way valve for current.
- When voltage is applied across a diode in such a way that the diode allows current, the diode is said to be *forward-biased*.
- When voltage is applied across a diode in such a way that the diode prohibits current, the diode is said to be *reverse-biased*.
- The voltage dropped across a conducting, forward-biased diode is called the *forward voltage*. Forward voltage for a diode varies only slightly for changes in forward current and temperature, and is fixed principally by the chemical composition of the P-N junction.
- Silicon diodes have a forward voltage of approximately 0.7 volts.
- Germanium diodes have a forward voltage of approximately 0.3 volts.
- The maximum reverse-bias voltage that a diode can withstand without "breaking down" is called the *Peak Inverse Voltage*, or *PIV* rating.

Transistors

- Short for 'Transfer Resistor'
- 3 materials; 2 junctions
- Bipolar versus Unipolar (FET)
- PNP or NPN
- 2N2222, 2N3904



Bipolar Transistors

PNP transistor

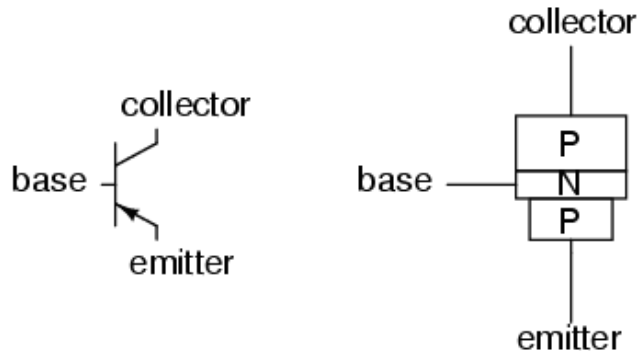

schematic symbol

physical diagram

NPN transistor

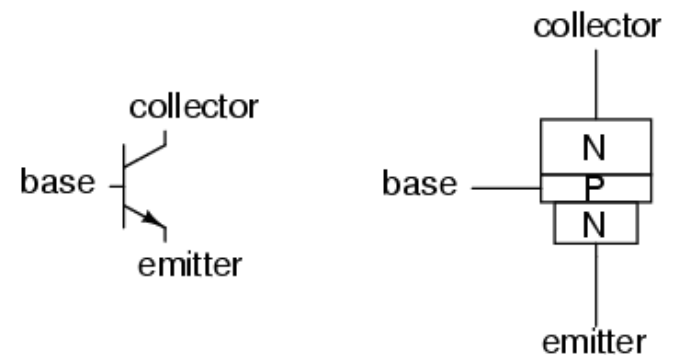

schematic symbol

physical diagram

NPN Transistor: A small current flowing from the emitter to the base controls a large current flowing from the emitter through the base to the collector

What is a RELAY?

- Let's forget about transistors for a moment....

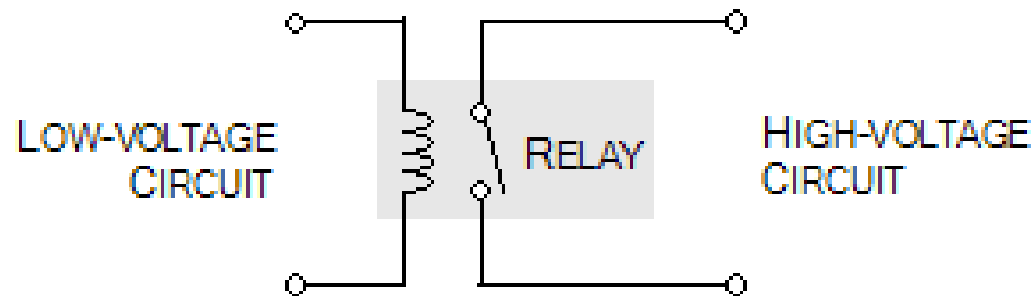

- Relays are electro-mechanical devices that contain a coil (electro-magnet) and a clapper-switch that moves

Relays are common for 'control' purposes

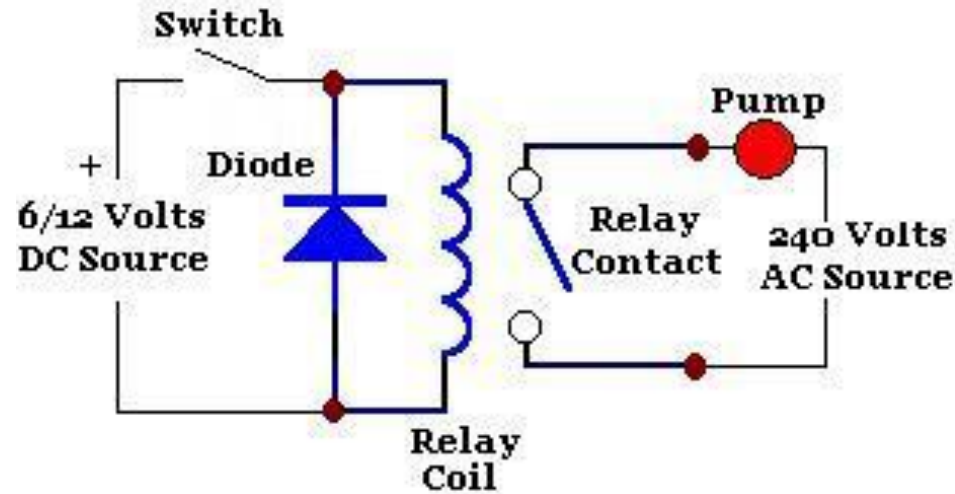

- A small voltage on the input causes the clapper to close.
- This switches 'on' the output voltage

Relays seem to amplify the signal !!

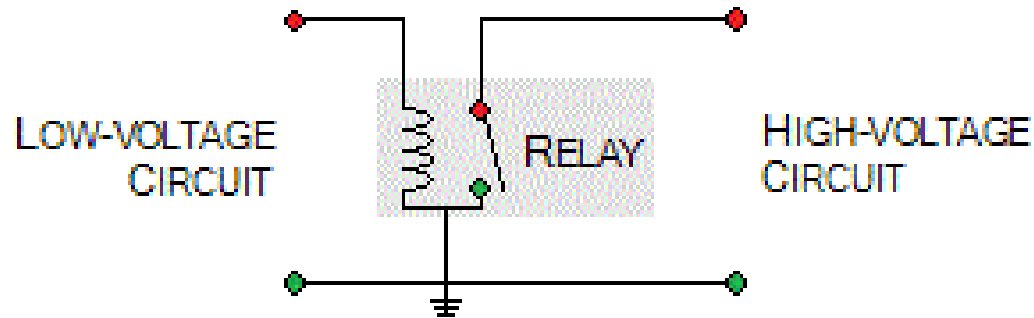

- This relay circuit will take a **SMALL** voltage as an **INPUT**
- Gives a **LARGE** voltage as an **OUTPUT**

Transistor amplifier circuit

- Small amounts of control current allow large amounts of signal to flow
- Ratio of 'control' to 'output' is the gain

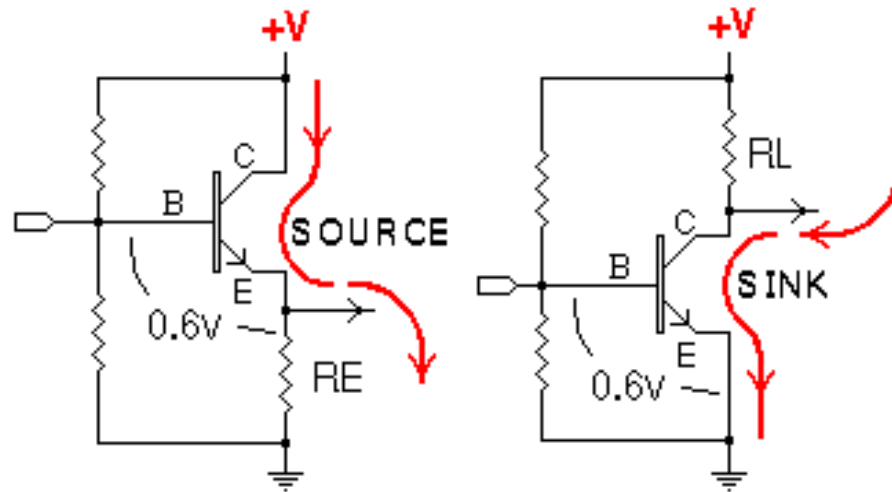

Transistor Man

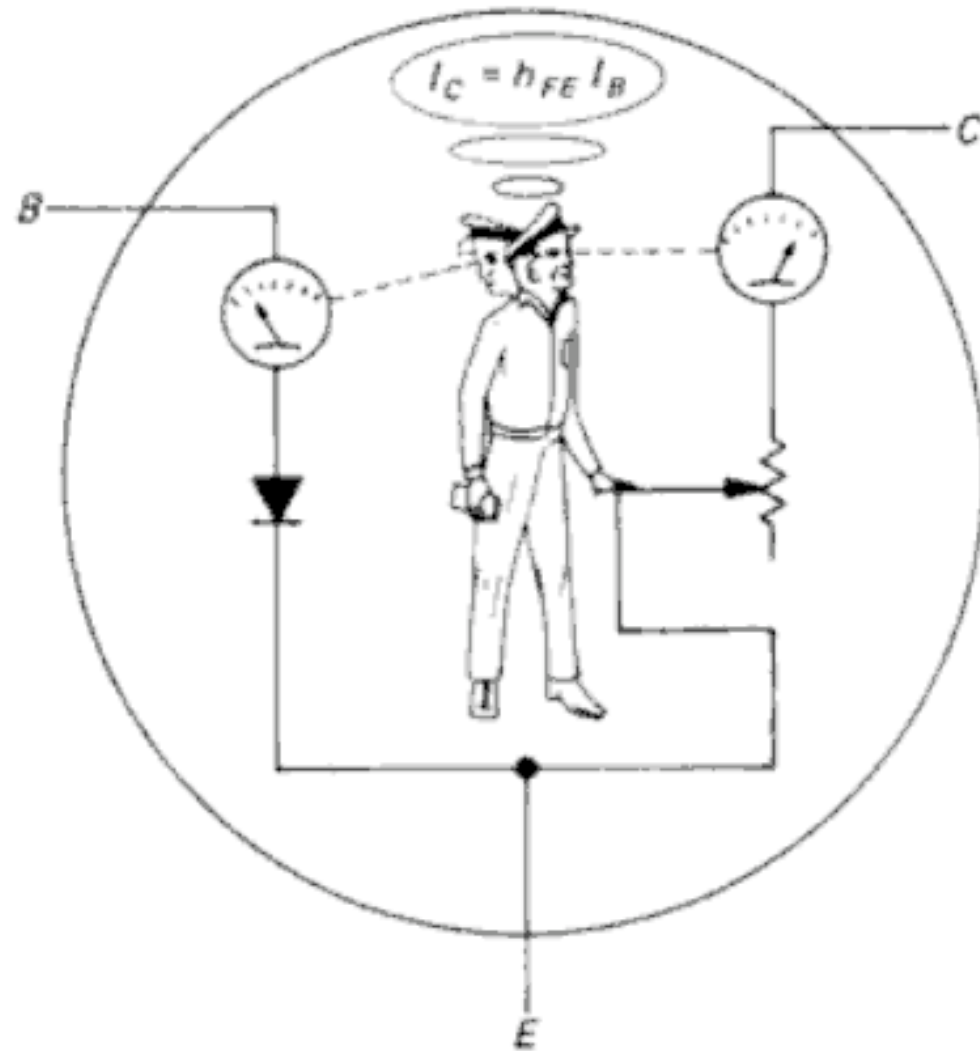

Field Effect Transistors

- Unlike bipolar transistors, FETs are normally 'on'
- The control voltage squeezes off the ability of current to flow

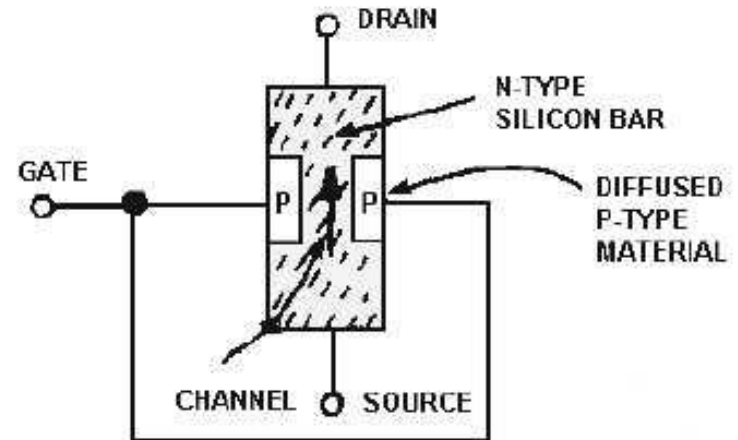
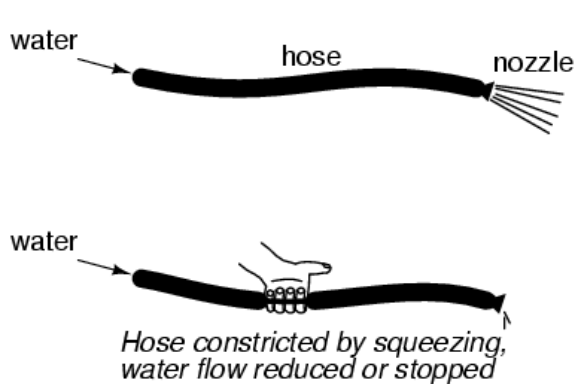

FET Symbols

- Multiple types of FETs, all derivatives of the same basic idea

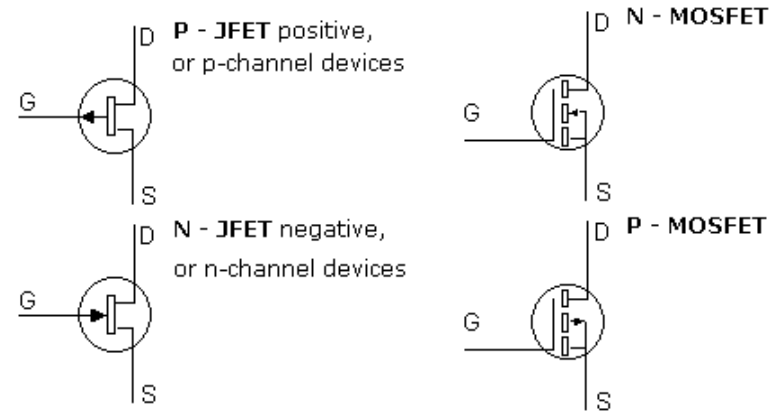
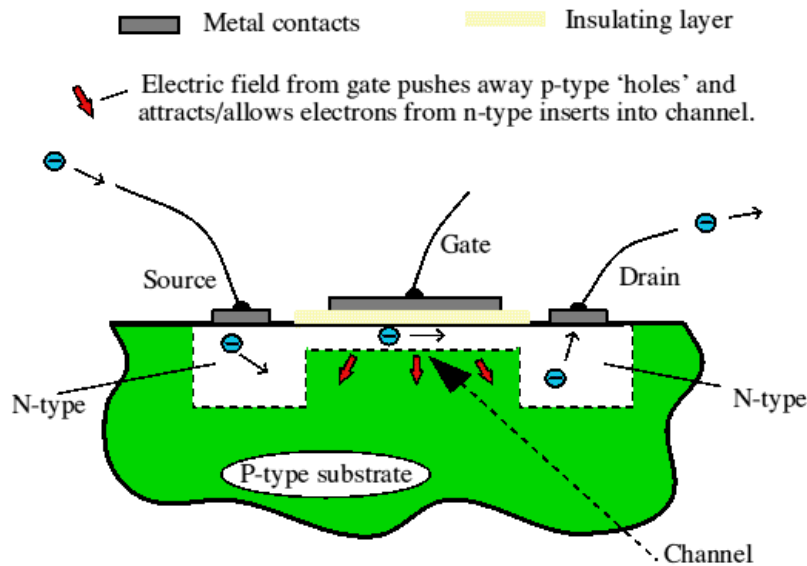

FET Facts

- Source: point at which the charge enters the channel
- Drain: exit point
- Gate: control point (same idea as the base in a bipolar transistor)
- JFET – Junction FET (operates reverse biased)
- IGFET – Insulated Gate FET
- MOSFET – Metal Oxide Silicon FET

Transistor Facts

- Breakdown voltage: Max safe voltage under any condition of operation
- Max Voltage: Max safe operating voltage; less than breakdown voltage
- Max Current: most important is $I_{\text{collector}}$
- Max Power: Deals with Heat Dissipation

Integrated Circuits

- Combines multiple devices into a single package
- Miniaturization
- High reliability
- Less costly than separate components

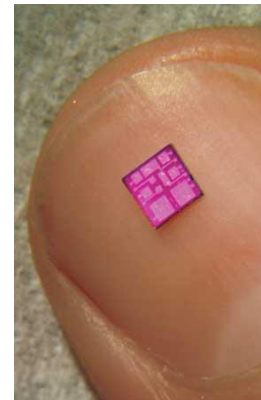
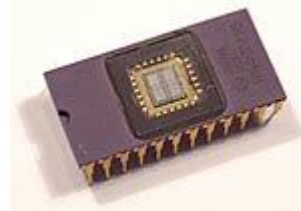

Vacuum Tubes

- Glass 'vacuum filled' container
- Heater filament
- Electrons stream from cathode to plate
- Grid controls flow (like a FET)

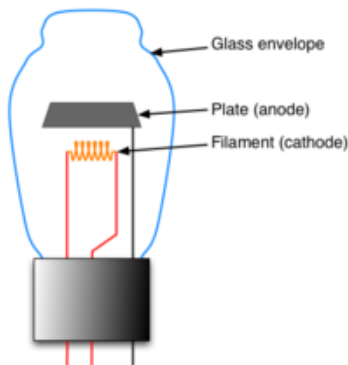
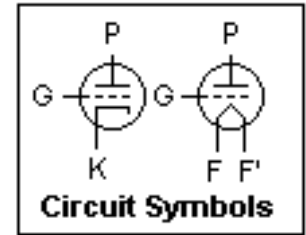

Diode

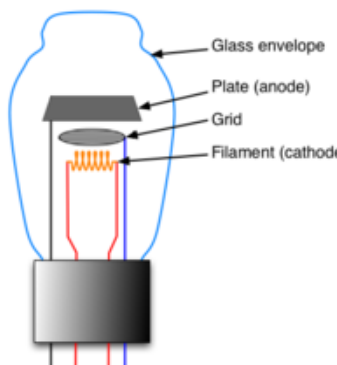

Triode

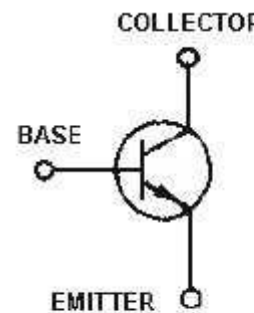

BIPOLAR

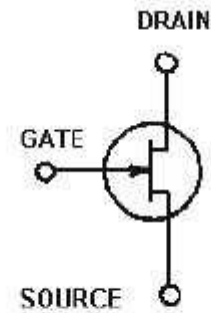

JFET

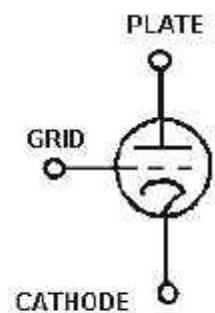

VACUUM TUBE

Vacuum Tubes

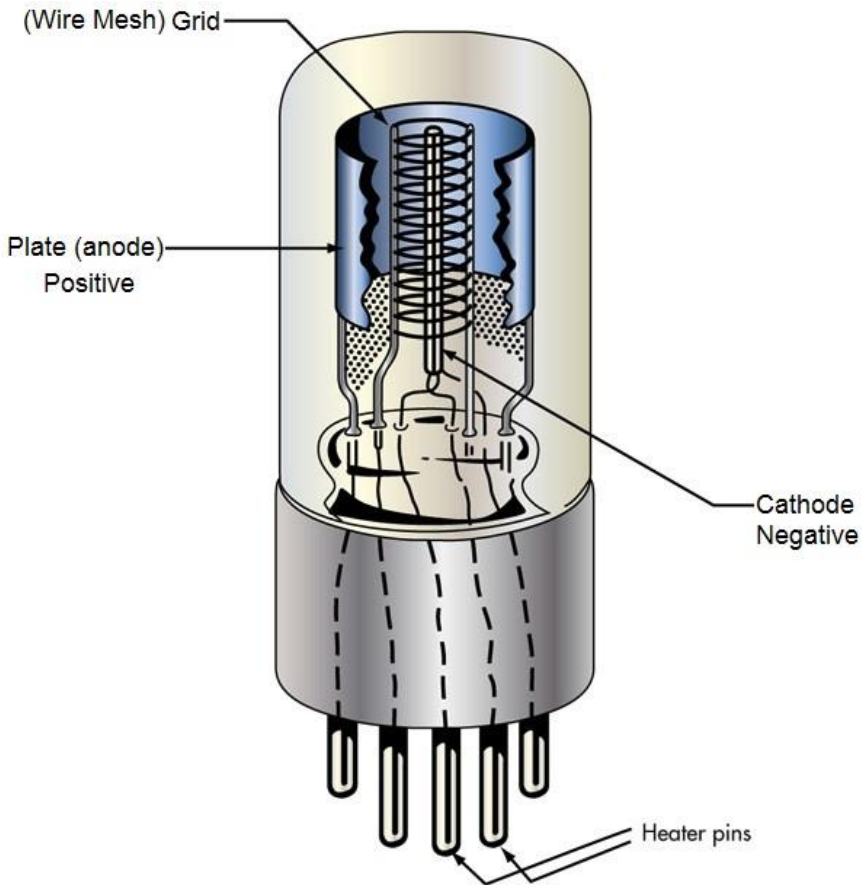

- The heater heats up the Cathode
- Electrons stream off the Cathode towards the Plate
- They must pass through the wire mesh of the Grid
- The Grid controls the flow similar to the Gate on a modern FET

Tube Facts

- Grid voltage = grid bias
- Total blockage occurs at cut-off bias
- Tubes can handle LARGE amounts of power
- Sometimes extra elements are added for stability and to reduce interaction between embedded elements
- Triode=3, tetrode=4, pentode=5



Tube numbering

- 1st digit = number of elements
- Last digit = plate dissipation
- Center letters;
 - X = external anode
 - C = ceramic (instead of glass)

Questions?

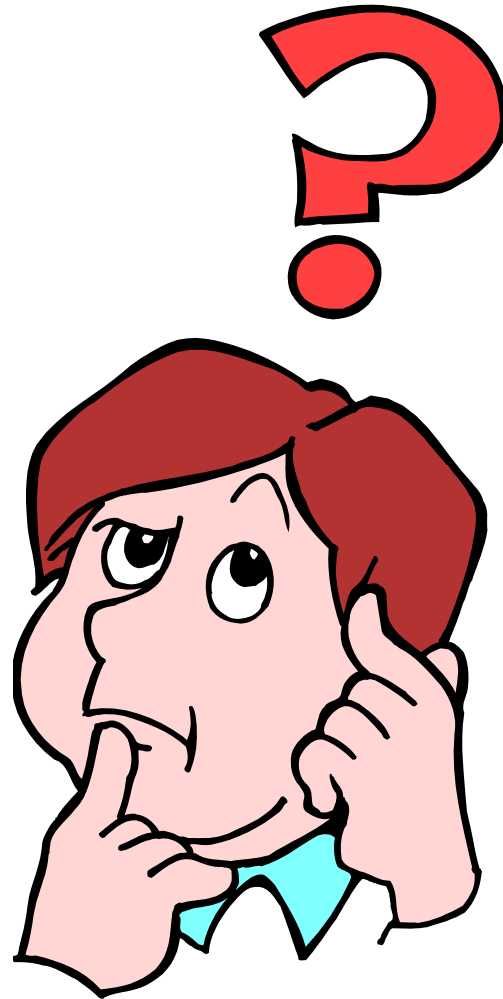

PART2 - Objectives

- Power Supplies: Changing AC to DC
- Describe the components of a power supply and their functions
- Identify components of a power supply using block diagram

Why a power supply?

Household voltage = 120vac up to 15a

10w Transmitter = 13.8vdc, 3a

100w Transmitter = 13.8vdc, 20a

Issues...

1. Voltage must be raised or lowered
2. Voltage must be changed from AC to DC
3. Ripple must be filtered
4. Constant/Steady = regulation

Factors...

- Input Voltage: Starting Point
- Output Voltage: Higher or lower?
- Rectification: AC to DC
- Filtering: getting rid of the bumps
- Output Current: The load
- Voltage Regulation: Steady within set limits

Block diagram - Overview

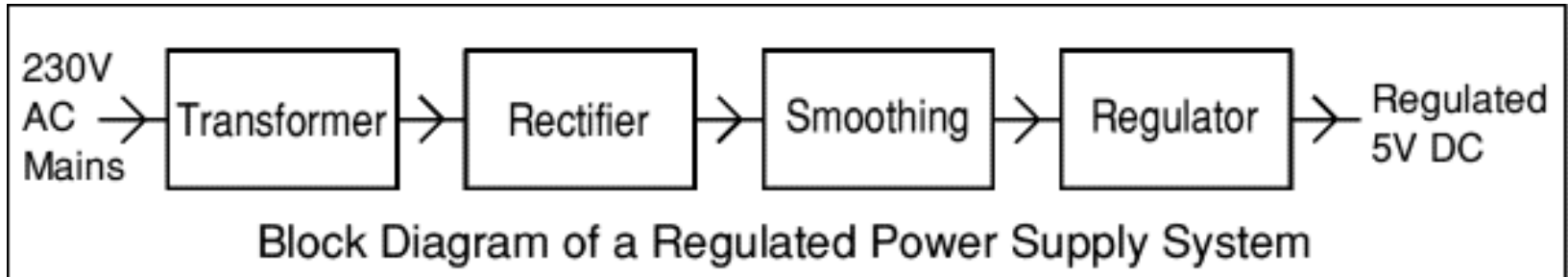

Transformer Only...

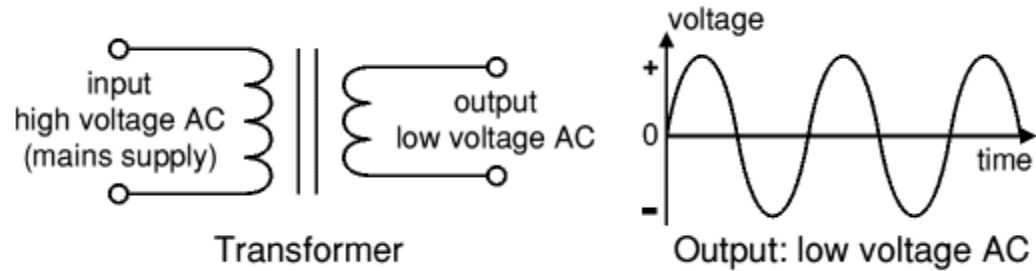

Rectification...

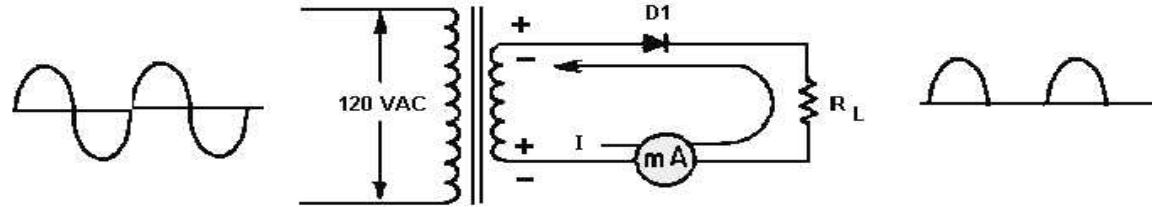

A. HALF-WAVE RECTIFIER

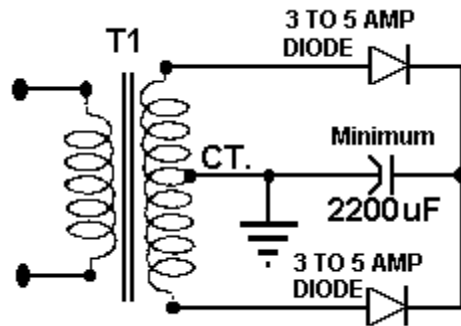

B. Full-wave Rectifier

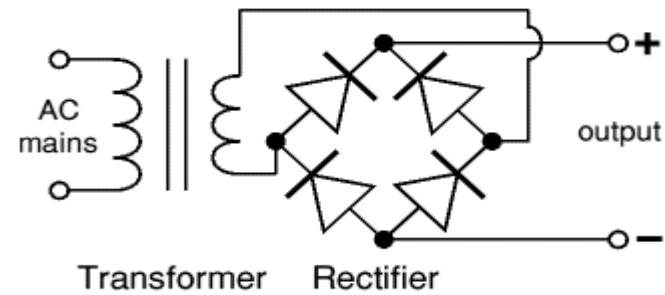

C. Full-wave Rectifier

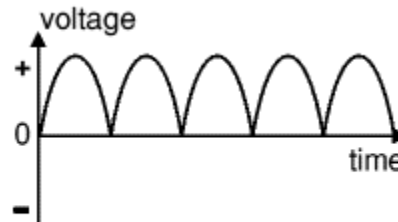

Output: varying DC

Smoothing...

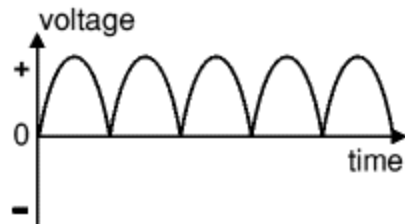
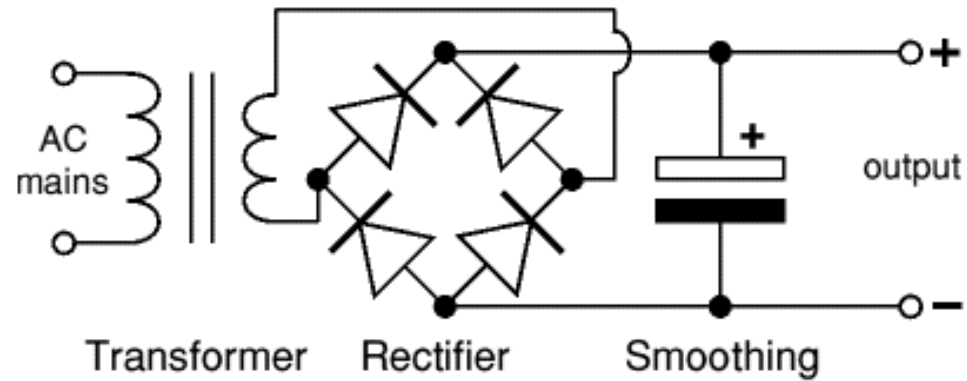

Input: Bumpy Pulsating DC

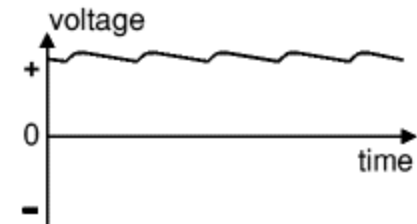

Output: smooth DC

Smoothing PART 2

Capacitors as power sources...

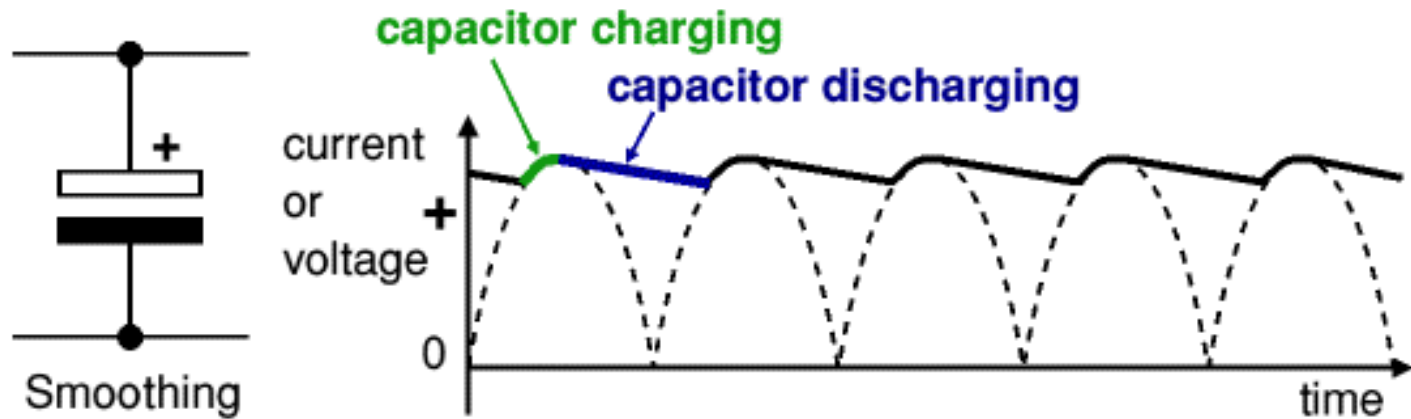

Rate of discharge depends on the load

Regulation...

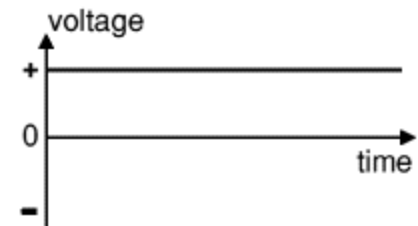
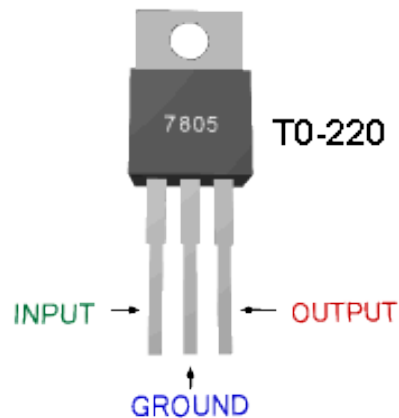
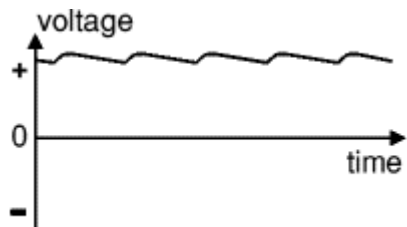
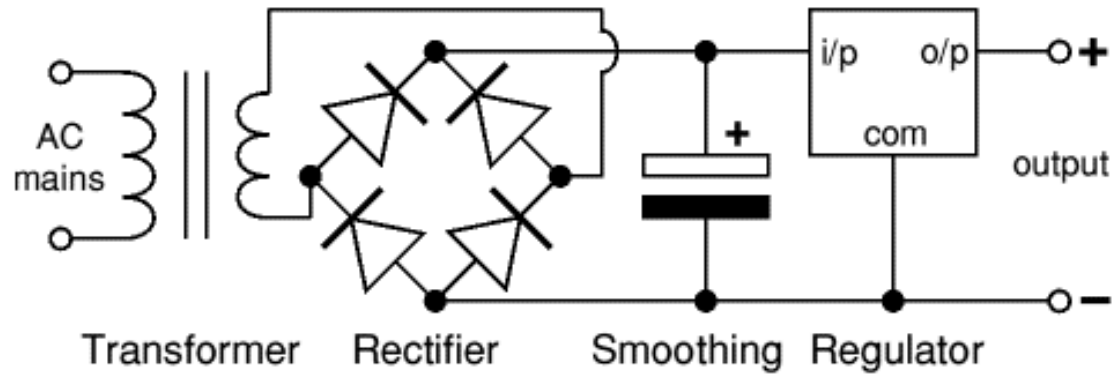

Schematic of a power supply

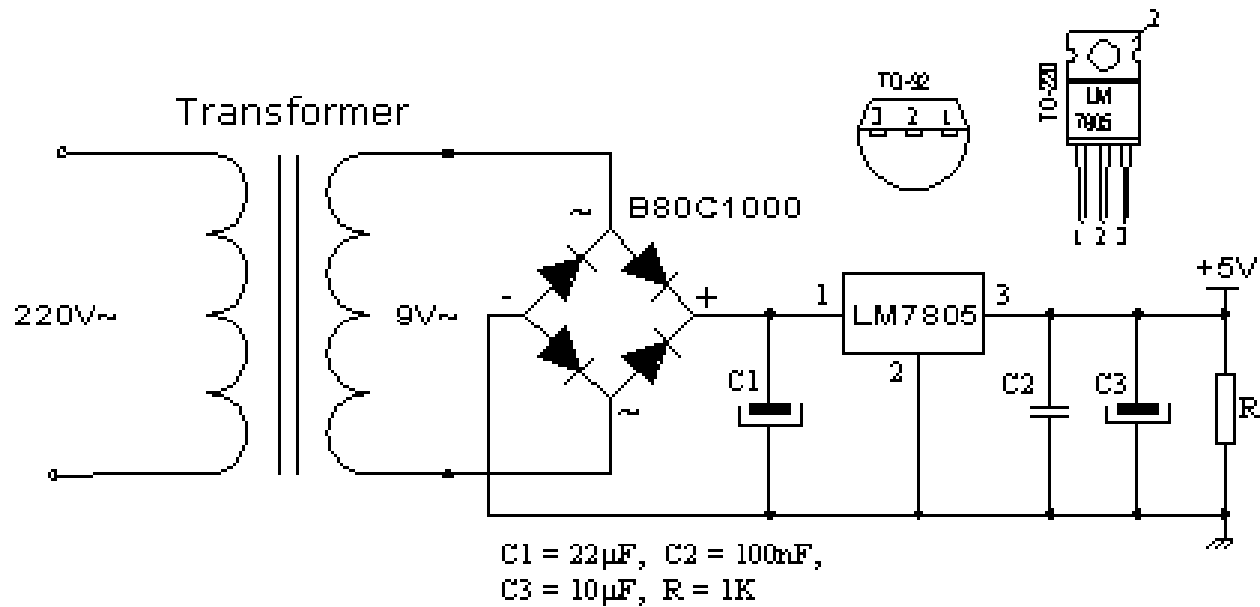

Power Supply Summary

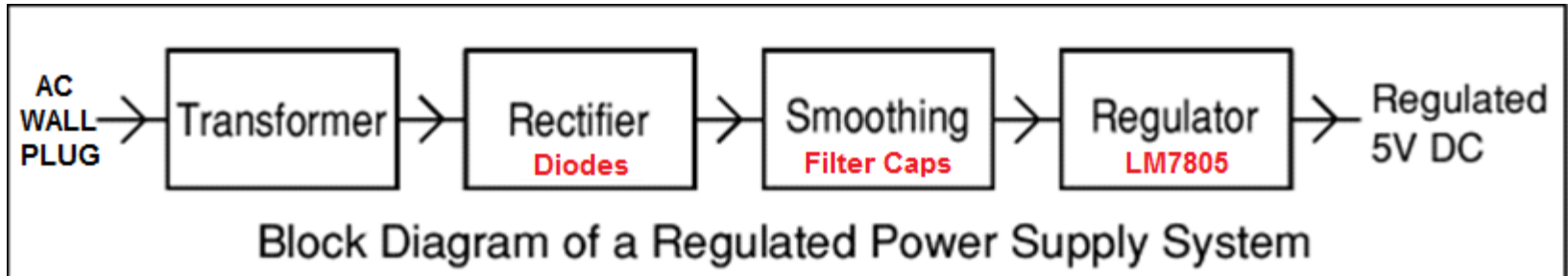

- **Transformer:** Drops high voltage AC to a lower voltage AC
- **Rectifier:** DIODES convert AC into pulsating DC
- **Smoothing:** Capacitor tries to filter the bumps
- **Regulator:** Smooth steady DC

Questions?

